



(19) **United States**

(12) **Patent Application Publication**
PARK et al.

(10) **Pub. No.: US 2012/0292645 A1**

(43) **Pub. Date: Nov. 22, 2012**

(54) **ORGANIC ELECTROLUMINESCENCE
DISPLAY AND MANUFACTURING METHOD
THEREOF**

Publication Classification

(51) **Int. Cl.**
H01L 51/52 (2006.01)
H01L 51/56 (2006.01)

(75) Inventors: **Sang-Il PARK**, Yongin-City (KR);
Tae-Kyung AHN, Yongin-City (KR)

(52) **U.S. Cl.** **257/88**; 438/34; 257/E51.018

(57) **ABSTRACT**

(73) Assignee: **SAMSUNG MOBILE DISPLAY
CO., LTD.**, Yongin-City (KR)

An organic electroluminescence display including: a gate line disposed on a substrate; a data line crossing the gate line; a TFT connected to the gate and data lines; a capacitor connected to the TFT; and an OLED connected to the TFT. A gate electrode of the TFT and a lower electrode of the capacitor are patterned from a first layer. A gate insulating layer disposed on the gate electrode and an insulating island disposed on the gate line are patterned from a second layer. A semiconductor island disposed on the insulating island and an active layer disposed on the gate insulating layer are patterned from a third layer. An insulating layer is disposed on the TFTs, the capacitor, and between the semiconductor island and the data line. An upper electrode of the capacitor, source/drain electrodes of the TFT, and the data line are patterned from a fourth layer.

(21) Appl. No.: **13/443,485**

(22) Filed: **Apr. 10, 2012**

(30) **Foreign Application Priority Data**

May 20, 2011 (KR) 10-2011-0047945

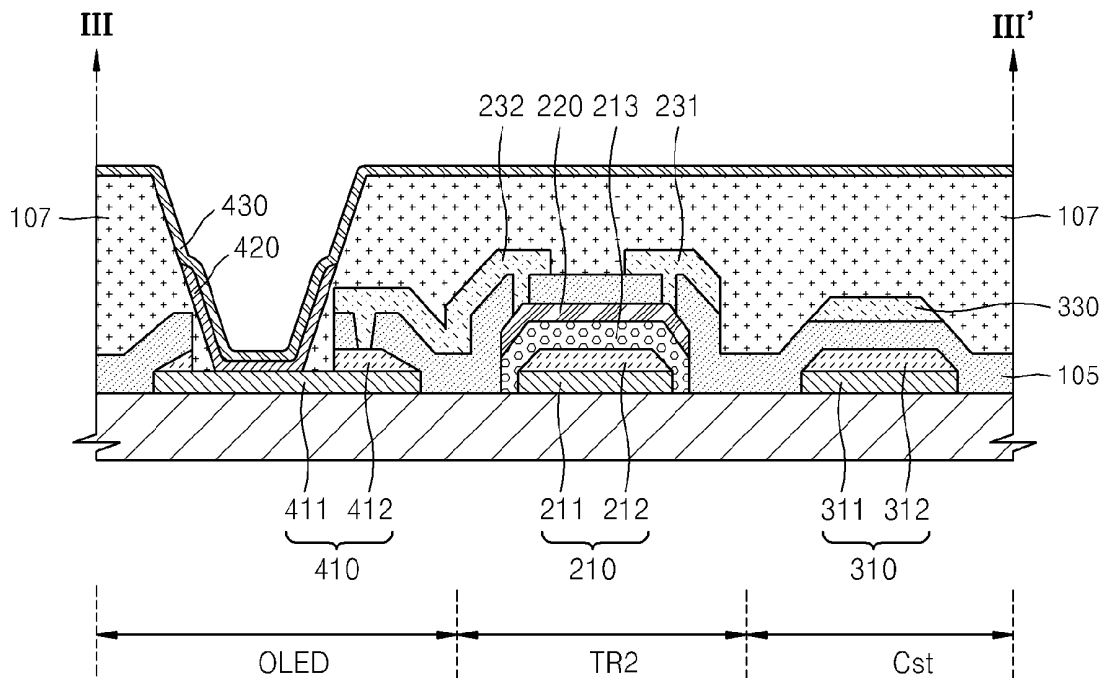

FIG. 1

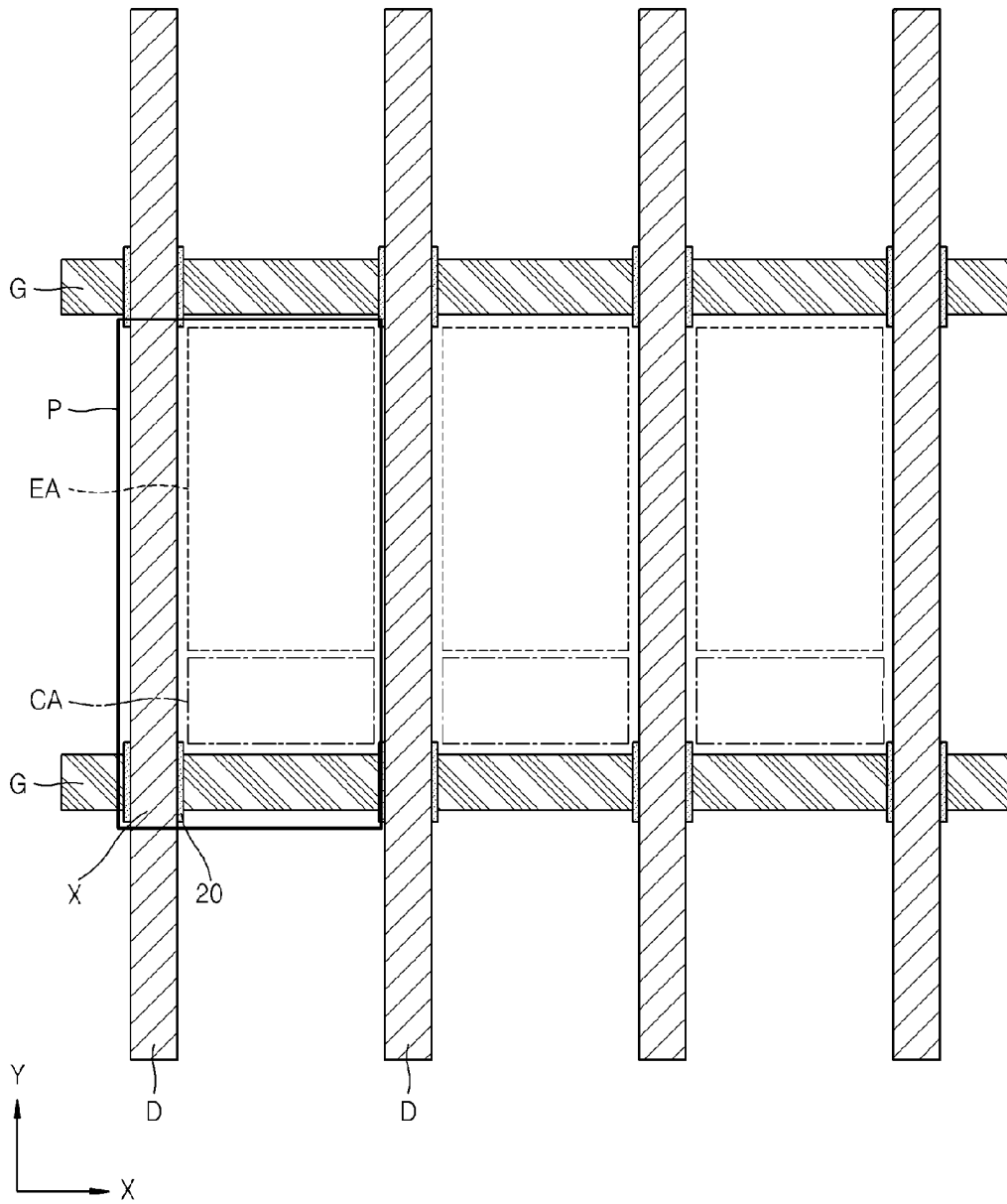

FIG. 3

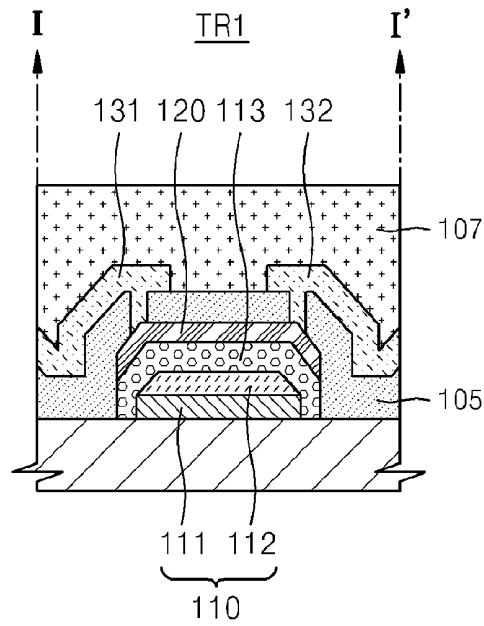

FIG. 4

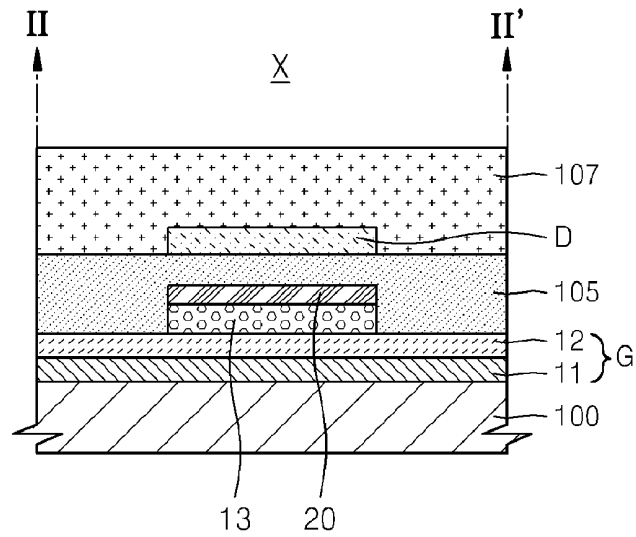

FIG. 5

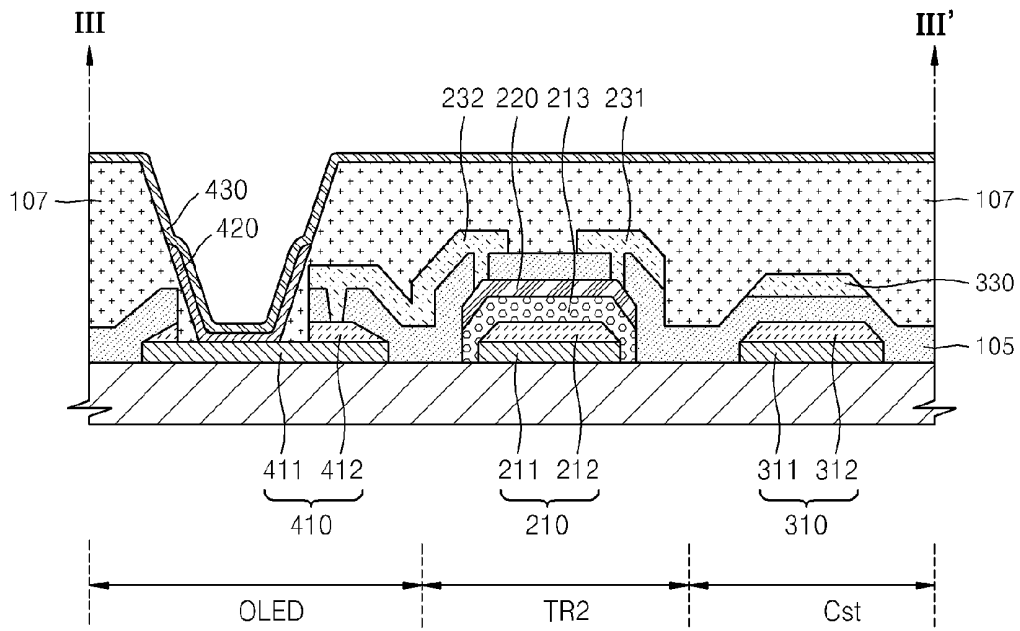

FIG. 6

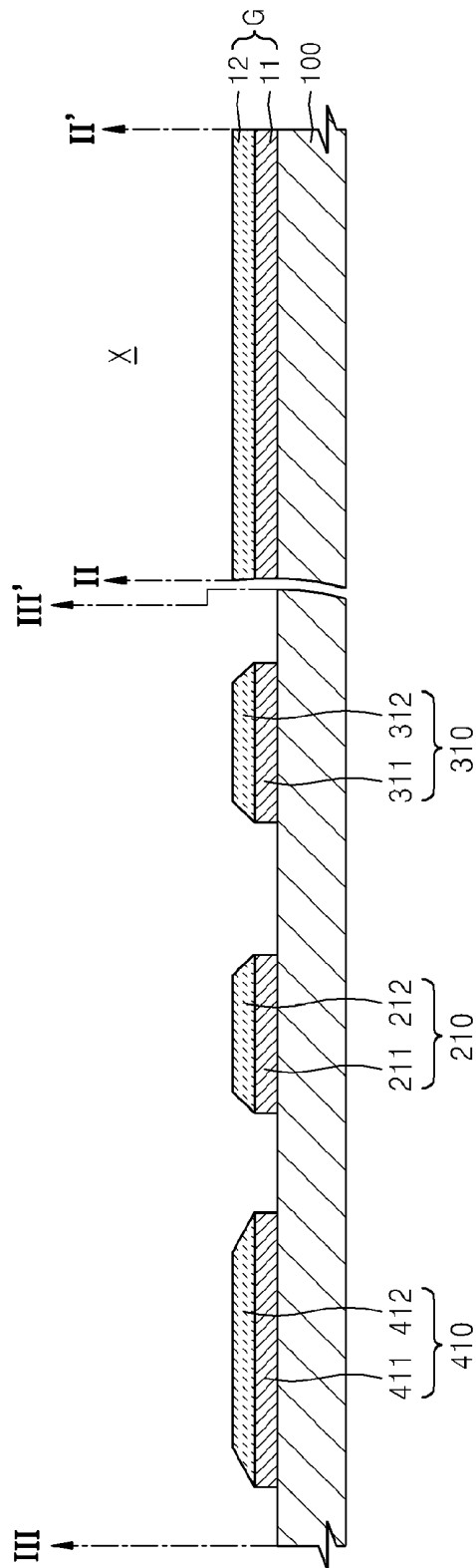

FIG. 7

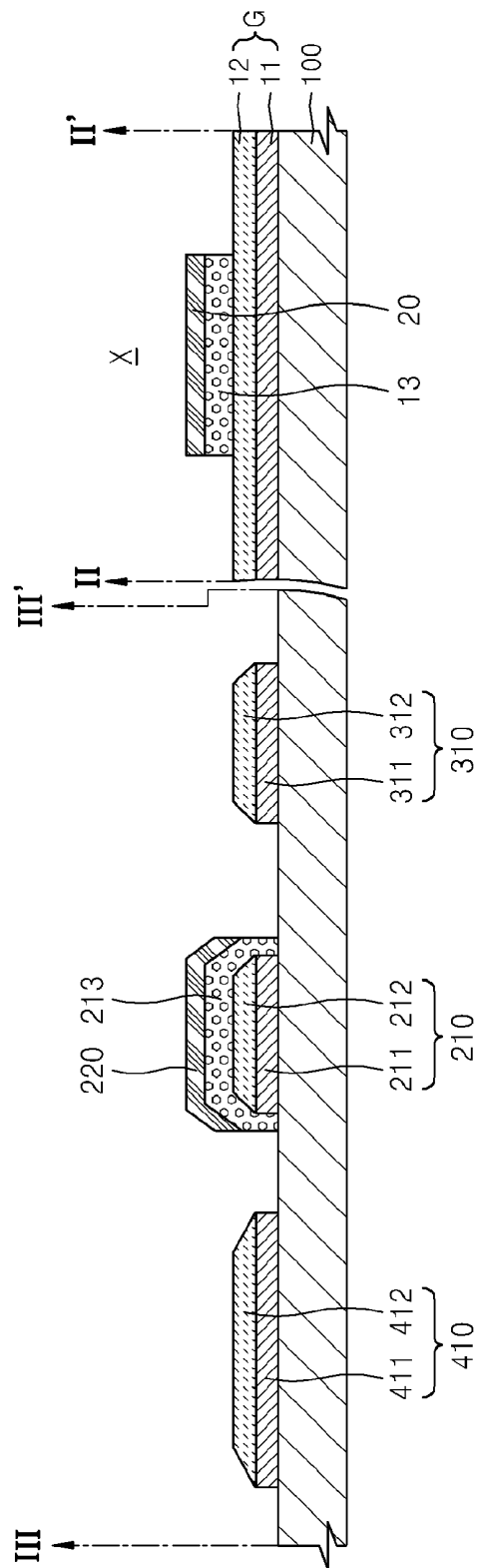

FIG. 8

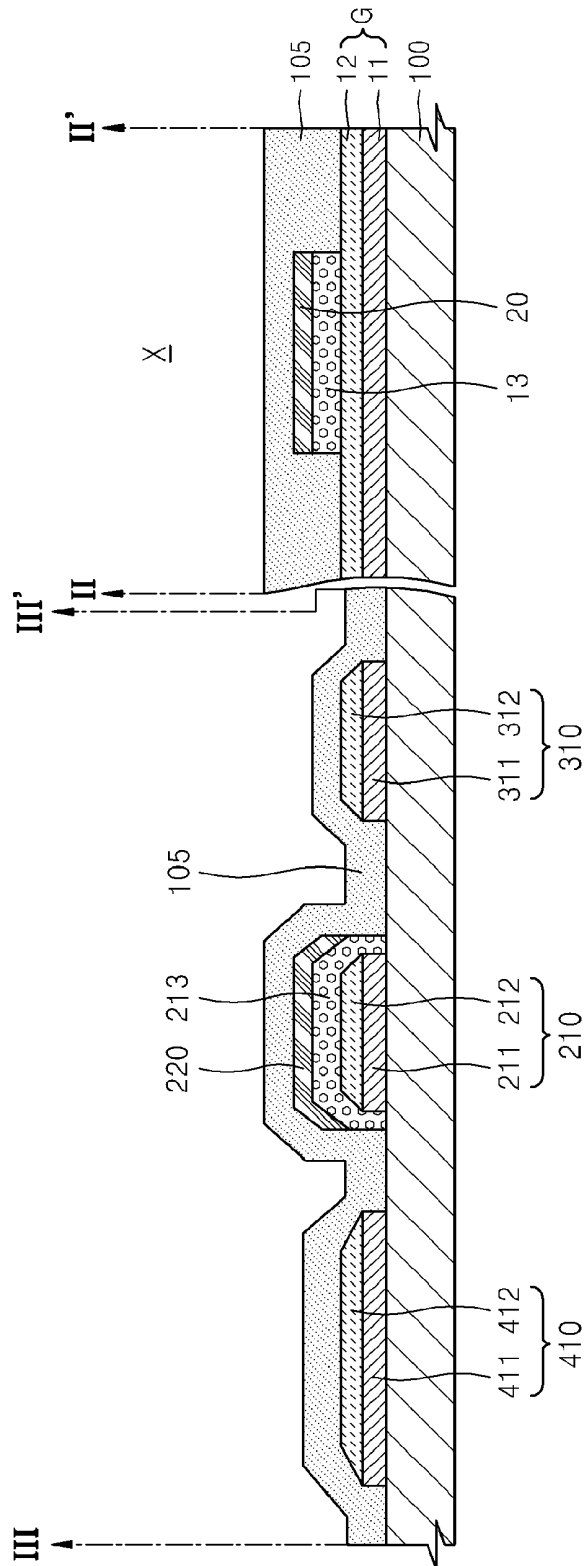

FIG. 11

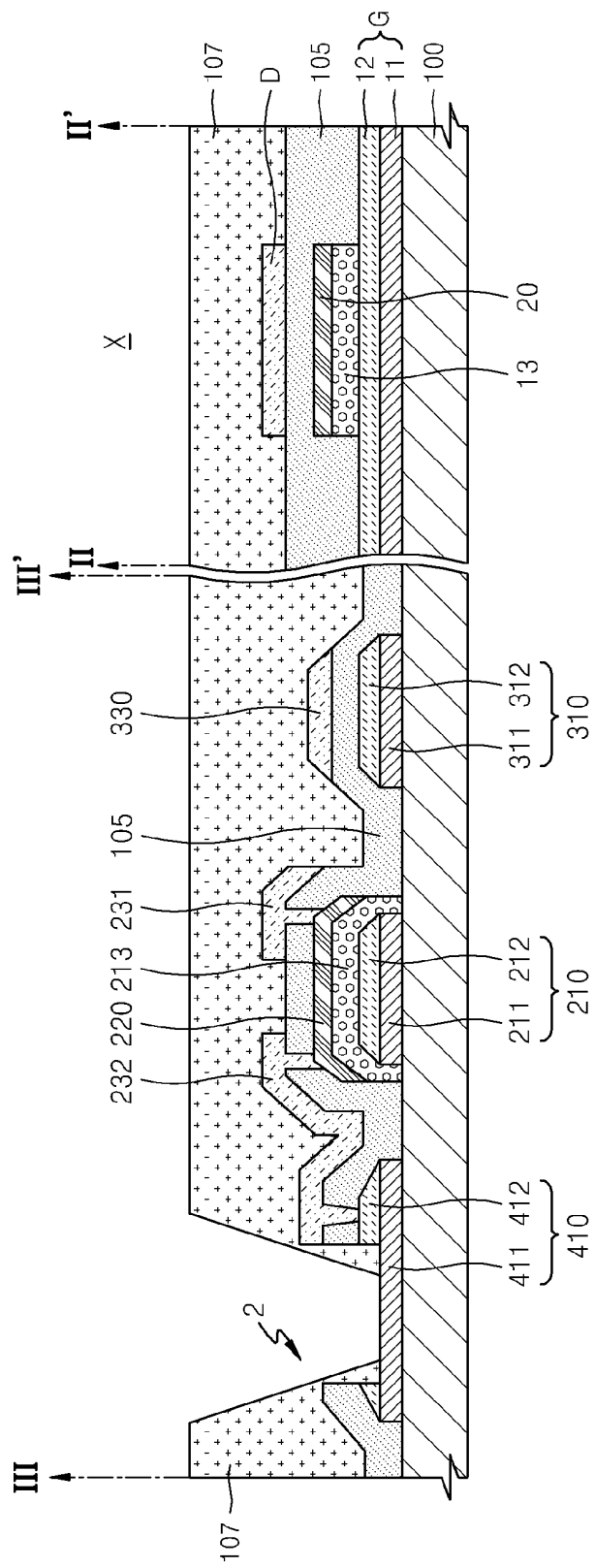
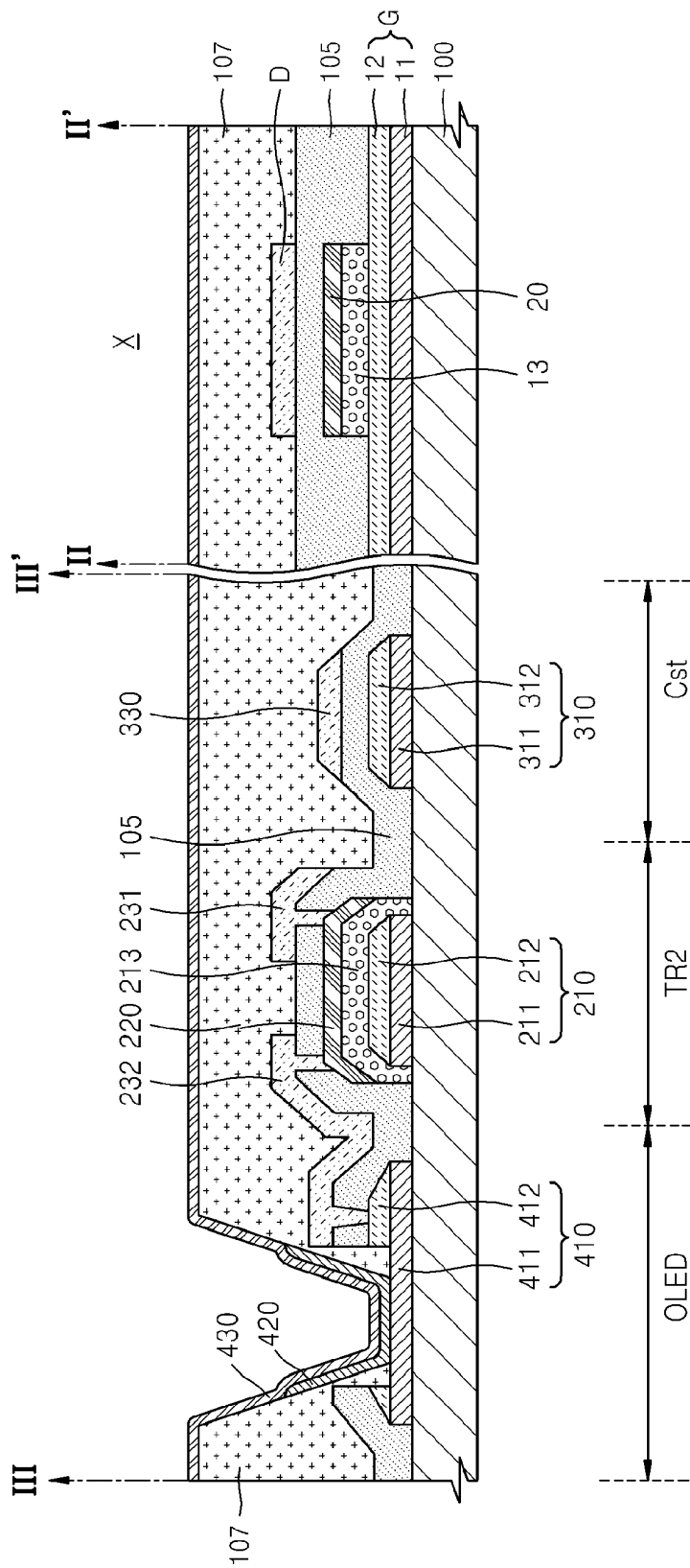

FIG. 12



ORGANIC ELECTROLUMINESCENCE DISPLAY AND MANUFACTURING METHOD THEREOF

CROSS-REFERENCE TO RELATED PATENT APPLICATION

[0001] This application claims priority from and the benefit of Korean Patent Application No. 10-2011-0047945, filed on May 20, 2011, which is hereby incorporated by reference for all purposes as if fully set forth herein.

BACKGROUND OF THE INVENTION

[0002] 1. Field of the Invention

[0003] Exemplary embodiments of the present invention relate to an organic electroluminescence display and a method of manufacturing the organic electroluminescence display.

[0004] 2. Discussion of the Background

[0005] In an active matrix organic electroluminescence display, pixels are formed between a matrix of gate lines and data lines. Each of the pixels includes thin-film transistors (TFTs), capacitors, and an organic light-emitting device connected to the TFTs and the capacitors. The organic light-emitting device generates light in response to an appropriate driving signal received from the TFTs and the capacitors, and thus, a desired image is displayed.

[0006] However, because the gate lines and data lines are arranged in a matrix, portions of the gate lines and the data lines overlap. A parasitic capacitance occurs at the overlapping portions. The parasitic capacitance makes the realization of a high resolution image difficult. Therefore, there is a need to reduce the parasitic capacitance.

SUMMARY OF THE INVENTION

[0007] Exemplary embodiments of the present invention provide an organic electroluminescence display that can reduce a parasitic capacitance between gate lines and data lines, and a method of manufacturing the organic electroluminescence display.

[0008] Additional features of the invention will be set forth in the description which follows, and in part will be apparent from the description, or may be learned by practice of the invention.

[0009] According to an aspect of the present invention, there is provided an organic electroluminescence display including: a gate line disposed on a substrate; a data line extending across the gate line in a crossing region; a first thin-film transistor (first TFT) that is electrically connected to the gate line and the data line, sequentially comprises a gate electrode, an active layer that comprises an oxide semiconductor, source and drain electrodes, and a gate insulating layer interposed between the gate electrode and the active layer; a capacitor that is electrically connected to the first TFT and includes a lower electrode and an upper electrode; an insulating layer interposed between the lower electrode and the upper electrode; a second TFT electrically connected to the capacitor; and an organic light-emitting diode (OLED) electrically connected to the second TFT. A semiconductor island separated from the active layer is disposed in the crossing region on the gate line. The semiconductor island comprises an oxide semiconductor and is formed of the same material as the active layer. A insulating island separated from the gate insulating layer is formed between the semiconduc-

tor island and the gate line, in the crossing region. The insulating island is formed of the same material as the gate insulating layer.

[0010] According to an aspect of the present invention, there is provided a method of manufacturing an organic electroluminescence display, the method comprising: patterning a first layer to form a gate electrode of a thin-film transistor (TFT), a lower electrode of a capacitor, and the gate line on a substrate; patterning a second layer to form a gate insulating layer on the gate electrode and an insulating island in the crossing region; patterning a third layer that comprises an oxide semiconductor to form an active layer on the gate insulating layer and a semiconductor island that is on the insulating island; forming a first insulating layer on the active layer, the lower electrode, and the semiconductor island; and patterning a fourth layer to form a source electrode and a drain electrode of the first TFT, an upper electrode of the capacitor, and a data line, on the first insulating layer.

[0011] It is to be understood that both the foregoing general description and the following detailed description are exemplary and explanatory and are intended to provide further explanation of the invention as claimed.

BRIEF DESCRIPTION OF THE DRAWINGS

[0012] The accompanying drawings, which are included to provide a further understanding of the invention and are incorporated in and constitute a part of this specification, illustrate embodiments of the invention, and together with the description serve to explain the principles of the invention.

[0013] FIG. 1 is a schematic plan view of an organic electroluminescence display, according to an exemplary embodiment of the present invention.

[0014] FIG. 2 is a magnified plan view of a portion of the organic electroluminescence display of FIG. 1.

[0015] FIG. 3 is a cross-sectional view taken along line I-I' of FIG. 2.

[0016] FIG. 4 is a cross-sectional view taken along line II-II' of FIG. 2.

[0017] FIG. 5 is a cross-sectional view taken along line III-III' of FIG. 2.

[0018] FIGS. 6, 7, 8, 9, 10, 11, and 12 are cross-sectional views showing a method of manufacturing the organic electroluminescence display of FIG. 2, according to an exemplary embodiment of the present invention.

DETAILED DESCRIPTION OF THE ILLUSTRATED EMBODIMENTS

[0019] The invention is described more fully hereinafter with reference to the accompanying drawings, in which exemplary embodiments of the invention are shown. This invention may, however, be embodied in many different forms and should not be construed as limited to the exemplary embodiments set forth herein. Rather, these exemplary embodiments are provided so that this disclosure is thorough, and will fully convey the scope of the invention to those skilled in the art. In the drawings, the size and relative sizes of layers and regions may be exaggerated for clarity. Like reference numerals in the drawings denote like elements.

[0020] It will be understood that, although the terms 'first', 'second', etc. may be used herein to describe various elements, these elements should not be limited by these terms. These terms are only used to distinguish one element from another.

[0021] The terminology used herein is for the purpose of describing embodiments only and is not intended to be limiting of exemplary embodiments. As used herein, the singular forms “a,” “an,” and “the,” are intended to include the plural forms as well, unless the context clearly indicates otherwise. It will be further understood that the terms “comprises,” “comprising,” “includes,” and/or “including,” when used herein, specify the presence of stated features, integers, steps, operations, elements, and/or components, but do not preclude the presence or addition of one or more other features, integers, steps, operations, elements, components, and/or groups thereof.

[0022] It will be understood that when an element or layer is referred to as being “on” or “connected to” another element or layer, it can be directly on or directly connected to the other element or layer, or intervening elements or layers may be present. In contrast, when an element is referred to as being “directly on” or “directly connected to” another element or layer, there are no intervening elements or layers present.

[0023] FIG. 1 is a schematic plan view of an organic electroluminescence display, according to an exemplary embodiment of the present invention. Referring to FIG. 1, the organic electroluminescence display includes gate lines G extending in an X-axis direction and data lines D extending in a Y-axis direction, which is substantially perpendicular to the X-axis direction. In FIG. 1, power lines (V in FIG. 2) are omitted.

[0024] Pixel regions P are defined by the gate lines G and the data lines D. The pixel regions P are rectangular regions formed where the data lines D and the gate lines G cross.

[0025] Each pixel region P includes a light-emitting region EA and a circuit region CA. The light-emitting region EA includes an organic light-emitting diode (OLED) and generates light. The circuit regions CA are electrically connected to the data lines D and the gate lines G, and each circuit region CA includes at least one thin-film transistor (TFT) and at least one capacitor. The circuit region CA is a region for driving the OLED.

[0026] Crossing regions X are regions where the data lines D and the gate lines G overlap. Each of the pixel regions P includes at least one crossing region X. The crossing region X includes a semiconductor island 20 and an insulating island 13 (refer to FIG. 4), which are separate from the circuit region CA.

[0027] FIG. 2 is a magnified plan view of the pixel region P of the organic electroluminescence display of FIG. 1. FIG. 3 is a cross-sectional view taken along line I-I' of FIG. 2, FIG. 4 is a cross-sectional view taken along line II-II' of FIG. 2, and FIG. 5 is a cross-sectional view taken along line III-III' of FIG. 2.

[0028] Referring to FIGS. 2 through 5, a first TFT TR1, a second TFT TR2, and a capacitor Cst are included in the circuit region CA. However, the number of transistors and capacitors is not limited thereto.

[0029] In FIGS. 2, 3, and 5, a bottom gate-type TFT is depicted. However, the present invention is not limited thereto.

[0030] Referring to FIG. 3, the first TFT TR1 functions as a switching transistor and is connected to the gate line G and the data line D. The first TFT TR1 is turned on in response to a gate signal applied to a source and outputs a data signal through a drain.

[0031] The first TFT TR1 includes a first gate electrode 110, a first active layer 120 that includes an oxide semiconductor, a first source electrode 131, and a first drain electrode

132 sequentially formed on a substrate in the stated order. The first gate electrode 110 protrudes from the gate line G. The first gate electrode 110 includes a first conductive layer 111 and a second conductive layer 112. The first conductive layer 111 includes a transparent conductive material, for example, ITO, IZO, and/or ZnO. The second conductive layer 112 includes a low resistance material, for example, Mo, Al, Pt, Pd, Au, and/or Cu.

[0032] Since the first gate electrode 110 is formed as a multiple layer structure, a pixel electrode 410 (refer to FIG. 5) and the first gate electrode 110 can be simultaneously formed of the same layer. In this way, the number of masks used for manufacturing an organic electroluminescence display can be reduced. Thus, manufacturing costs and processing steps can be reduced.

[0033] A first gate insulating layer 113 is formed on the first gate electrode 110. The first gate insulating layer 113 insulates the first gate electrode 110 from the first active layer 120. The first gate insulating layer 113 may include an inorganic material, such as SiO₂ or SiN_x, or an organic material.

[0034] The first gate insulating layer 113 is not formed on the entire surface of the substrate 100. Instead, the first gate insulating layer 113 is formed between the first gate electrode 110 and the first active layer 120 of the first TFT TR1. Also, a second gate insulating layer 213 corresponding to the first gate insulating layer 113 is formed between a second gate electrode 210 and a second active layer 220 of the second TFT TR2. The insulating island 13 corresponding to the first gate insulating layer 113 is formed between the gate line G and the semiconductor island 20 of the crossing region X.

[0035] An insulating layer corresponding to the first gate insulating layer 113 is not formed between an upper electrode 330 and a lower electrode 310 of the capacitor Cst. Accordingly, a distance between the upper and lower electrodes 330 and 310 of the capacitor Cst is reduced, thereby increasing a charge capacitance of the capacitor Cst. A distance between the data lines D and the gate lines G is increased by the insulating island 13 in the crossing region X, thereby reducing a parasitic capacitance at the crossing region X.

[0036] The first active layer 120 is formed on the first gate insulating layer 113. According to an aspect of the present invention, the first active layer 120 includes an oxide semiconductor. For example, the first active layer 120 may have the formula $a(\text{In}_2\text{O}_3)_b(\text{Ga}_2\text{O}_3)_c(\text{ZnO})$ (G-I—Z—O) (where a, b, and c are real numbers that respectively satisfy $a \geq 0$, $b \geq 0$, and $c > 0$) or may be a Hf—In—Zn—O layer.

[0037] A first insulating layer 105 is formed on the first active layer 120, to insulate the first active layer 120 from the first source electrode 131 and the first drain electrode 132. The first insulating layer 105 may function as an etch stop layer (ESL) to protect the first active layer 120, and may include an inorganic material, such as SiO₂ or SiN_x, or an organic material. Unlike the first gate insulating layer 113, the first insulating layer 105 is formed on the entire surface of the substrate 100.

[0038] The first source electrode 131 and the first drain electrode 132 are formed on regions of the first insulating layer 105 corresponding to the first active layer 120. The first source electrode 131 extends from the data line D. A pixel-defining layer 107 is formed thereon.

[0039] Referring to FIG. 4, the crossing region X includes the gate line G, the insulating island 13, the semiconductor island 20, and the data line D. The gate line G is formed from the same layer of material as the first gate electrode 110. The

first gate electrode **110** extends from the gate line G. Accordingly, in FIG. 4, a transparent conductive layer **11** corresponds to the first conductive layer **111** of the first gate electrode **110**, and a low resistance conductive layer **12** corresponds to the second conductive layer **112** of the first gate electrode **110**.

[0040] The insulating island **13** is formed on the gate line G in the crossing region X. The insulating island **13** and the first gate insulating layer **113** are formed simultaneously from the same material. The insulating island **13** is independently formed and is formed only in the crossing region X. The insulating island **13** is in the form of an island that is separated from the first gate insulating layer **113**. The insulating island **13** may have a width in the X-axis direction that is equal to or greater than that of the data line D. The insulating island **13** may have a length in the Y-axis direction that is equal to or greater than that of the gate line G. If the insulating island **13** has smaller dimensions than the data line D and the gate line G, a parasitic capacitance in the crossing region X may be increased.

[0041] The semiconductor island **20** is formed on the insulating island **13**. The semiconductor island **20** and the first active layer **120** are formed simultaneously, using the same material used to form the first active layer **120**. Thus, the semiconductor island **20** may include an oxide semiconductor. The semiconductor island **20** is formed as an island in the crossing region X and is separate from the first active layer **120**. The semiconductor island **20** may have an area equal to that of the insulating island **13**. For example, a width of the semiconductor island **20** in the X-axis direction may be equal to that of the insulating island **13**, and a length of the semiconductor island in the Y-axis direction may be equal to that of the insulating island **13**.

[0042] The first insulating layer **105** is formed on the semiconductor island **20**. As described above, because the first insulating layer **105** is formed on the entire surface of the substrate **100**, the first insulating layer **105** is also formed in the crossing region X.

[0043] The data line D is formed on the first insulating layer **105**. The data line D extends substantially perpendicular to the gate line G. The data line D, the first source electrode **131**, and the first drain electrode **132** are formed from the same layer of material.

[0044] Since the insulating island **13** and the semiconductor island **20** are formed in the crossing region X, the parasitic capacitance in the crossing region X may be reduced. A capacitance between the two electrodes is determined according to Equation 1 below. In Equation 1, C is charge capacity, c is dielectric constant, A is area of electrode, and d is distance between electrodes.

$$C = \epsilon \frac{A}{d} \quad \text{[Equation 1]}$$

[0045] That is, because the data line D and the gate line G overlap in the crossing region X, a charge capacity formed by the data line D and the gate line G is determined by the dielectric constant ϵ of each of the first insulating layer **105**, the semiconductor island **20**, and the insulating island **13**, between the data line D and the gate line G, the distance d between the data line D and the gate line G, and the area A of the region where the data line D and the gate line G overlap.

[0046] Because the insulating island **13** and the semiconductor island **20** are formed between the data line D and the gate line G, the distance d between the data line D and the gate line G may be increased. Thus, the parasitic capacitance in the crossing region X is reduced.

[0047] Referring to FIG. 5, the capacitor Cst is electrically connected to the first TFT TR1 and stores applied data signals. The capacitor Cst includes the lower electrode **310**, the upper electrode **330**, and the first insulating layer **105** interposed between the lower electrode **310** and the upper electrode **330**.

[0048] The lower electrode **310** is formed on the substrate **100**, from the same layer of material as the first gate electrode **110**. Accordingly, the lower electrode **310** includes a first layer **311** and a second layer **312**. The first layer **311** includes the same transparent conductive material as the first conductive layer **111**. The second layer **312** includes the same low resistance conductive material as the second conductive layer **112**.

[0049] The upper electrode **330** is formed from the same layer or material as the first source electrode **131** and the first drain electrode **132**. The upper electrode **330** extends from the power line V. The power line V may be formed from the same layer of material as the data line D. The first insulating layer **105** is interposed between the lower electrode **310** and the upper electrode **330**.

[0050] Since the first insulating layer **105** is interposed between the lower electrode **310** and the upper electrode **330** and is formed of a single layer, the charge capacity of the capacitor Cst may be increased. Referring to Equation 1, because a charge capacity of the capacitor Cst is inversely proportional to a distance d between the two electrodes, the charge capacity may be increased as the distance between the two electrodes decreases. A large capacitance can be produced, because only the first insulating layer **105** is interposed between the lower electrode **310** and the upper electrode **330**.

[0051] According to the current embodiment, the parasitic capacitance in the crossing region X can be reduced and the charge capacity of the capacitor Cst can be increased. If the first insulating layer **105** is thickly formed or the first gate insulating layer **113** is formed on the entire surface of the substrate to reduce the parasitic capacitance in the crossing region X, the charge capacity of the capacitor Cst may be reduced. However, because the insulating island **13** and the semiconductor island **20** are independently formed, this effect may be prevented.

[0052] Referring to FIG. 5, the second TFT TR2 functions as a driving transistor, by being electrically connected to the capacitor Cst. The OLED is connected to a drain of the second TFT TR2, and the second TFT TR2 outputs a driving current for driving the OLED, when turned on.

[0053] The second TFT TR2 includes the second gate electrode **210**, the second active layer **220** that includes an oxide semiconductor, a second source electrode **231** and a second drain electrode **232**. Also, a second gate insulating layer **213** is interposed between the second gate electrode **210** and the second active layer **220**. The configuration of the second TFT TR2 corresponds to the configuration of the first TFT TR1, and thus, the description thereof will not be repeated.

[0054] In particular, the second gate electrode **210**, the second active layer **220**, the second source electrode **231**, and the second drain electrode **232** respectively correspond to the first gate electrode **110**, the first active layer **120**, the first source electrode **131**, and the first drain electrode **132**. The second

gate insulating layer **213** corresponds to the first gate insulating layer **113**. A transparent conductive layer **211** and a low resistance conductive layer **212** respectively correspond to the first conductive layer **111** and the second conductive layer **112**.

[0055] The second drain electrode **232** of the second TFT TR2 is electrically connected to the OLED. The OLED includes a pixel electrode **410**, a facing (opposing) electrode **430**, and an organic light-emitting layer **420** interposed between the pixel electrode **410** and the facing electrode **430**.

[0056] The pixel electrode **410** is formed from the same layer or material as the first gate electrode **110**. The pixel electrode **410**, similar to the first gate electrode **110**, includes a first electrode layer **411** and a second electrode layer **412**. The first electrode layer **411** is formed of a transparent conductive material and directly contacts the organic light-emitting layer **420**. The first electrode layer **411** includes a transparent conductive material such as ITO, IZO, or ZnO and is exposed by removing a portion of the second electrode layer **412**, to make the connection. The second electrode layer **412** includes a low resistance conductive material and directly contacts the second drain electrode **232**.

[0057] The pixel electrode **410**, the first and second gate electrodes **110** and **210**, and the lower electrode **310** of the capacitor Cst can be simultaneously formed. Thus, a manufacturing process thereof can be simplified.

[0058] The facing electrode **430** may include a metal having a low work function, such as Ag, Mg, Al, Pt, Pd, Au, Ni, Nd, Ir, Cr, and/or Li. The pixel electrode **410** may function as an anode electrode, and the facing electrode **430** may function as a cathode electrode. However, the present invention is not limited thereto, and the polarities of the pixel electrode **410** and the facing electrode **430** may be reversed.

[0059] The organic light-emitting layer **420** may be formed by stacking a hole injection/transport layer, a light-emitting layer, and an electron injection/transport layer, or by selectively stacking some of the layers described above. However, at least the light-emitting layer should be included. Although not shown, a protective layer may further be formed on the facing electrode **430**, and a sealing operation may be performed using glass.

[0060] The pixel-defining layer **107** may be formed to entirely cover the first and second TFTs TR1 and TR2, the capacitor Cst, and the pixel electrode **410**. An opening that exposes the pixel electrode **410** is formed in the pixel-defining layer **107**. The organic light-emitting layer **420** and the facing electrode **430** are formed on the exposed portion of the first electrode layer **411**.

[0061] FIGS. 6 through 12 are cross-sectional views showing a method of manufacturing the organic electroluminescence display of FIG. 2, according to an exemplary embodiment of the present invention. In FIGS. 6 through 12, for convenience of explanation, a method of manufacturing the second TFT TR2, the capacitor Cst, the OLED, and the crossing region X of the constituent elements in the pixel region P included in FIGS. 4 and 5 is shown. The first TFT TR1 is manufactured in the same method as the second TFT TR2, and thus, the description thereof will not be repeated.

[0062] The organic electroluminescence display may be manufactured using five masks. FIGS. 6, 7, 9, 10, and 11 are cross-sectional views of the organic electroluminescence display respectively manufactured by using first, second, third, fourth, and fifth masks.

[0063] As described above, because the second gate electrode **210**, the lower electrode **310**, and the pixel electrode **410** are formed as double layers, the organic electroluminescence display can be manufactured using only five masks. Therefore, process efficiency is increased.

[0064] Referring to FIG. 6, the second gate electrode **210** of the second TFT TR2, the lower electrode **310** of the capacitor Cst, and the gate line G are simultaneously formed from the same layers of material, on the substrate **100**. More specifically, after forming a transparent conductive material layer on an entire surface of the substrate **100**, a low resistance conductive material layer is formed on the transparent conductive layer. Afterwards, the second gate electrode **210**, the lower electrode **310**, the gate line G, and the pixel electrode **410** are patterned using a first mask.

[0065] Accordingly, the second gate electrode **210**, the lower electrode **310**, the gate line G, and the pixel electrode **410** respectively include double layers and may be formed simultaneously. Although not shown, a buffer layer (not shown) may also be formed on the substrate **100**.

[0066] Referring to FIG. 7, the second gate insulating layer **213** is formed on the second gate electrode **210**, and the insulating island **13** is formed in the crossing region X. The insulating island **13** and the second gate insulating layer **213** are formed simultaneously from the same layer of material.

[0067] More specifically, an insulating layer is formed on an entire surface of the resultant structure of FIG. 6. The insulating layer is patterned to form the second gate insulating layer **213** on the second gate electrode **210** and the insulating island **13** in the crossing region X, using a second mask.

[0068] Accordingly, the second gate insulating layer **213** and the insulating island **13** may be simultaneously formed on the same layer and using the same material. Also, the second gate insulating layer **213** and the insulating island **13** are separated from each other.

[0069] Also, referring to FIG. 7, the second active layer **220** that includes an oxide semiconductor is formed on the second gate insulating layer **213**, and the semiconductor island **20** is formed on the insulating island **13** using the same layer of material. More specifically, after forming a layer that includes an oxide semiconductor on an entire surface of the substrate **100**, the layer is patterned to form the second active layer **220** on the second gate insulating layer **213** and the semiconductor island **20** on the insulating island **13**, using the second mask.

[0070] Accordingly, the second active layer **220** and the semiconductor island **20** may be formed using the same layer of material. Also, the semiconductor island **20** and the second active layer **220** are separated from each other and may be independently formed.

[0071] Meanwhile, for convenience of explanation, the process of forming and patterning of the insulating layer and the process of forming and patterning of the layer that includes an oxide semiconductor are separately described. However, after sequentially forming the insulating layer and the layer that includes an oxide semiconductor, the structure of FIG. 7 can be formed by a single patterning operation, using the second mask.

[0072] According to the current embodiment, in order to have a minimum parasitic capacitance in the crossing region X, the semiconductor island **20** and the insulating island **13** may be formed to have the same area. For example, a width of the semiconductor island **20** in the X-axis direction may be equal to that of the insulating island **13**, and a length of the

semiconductor island **20** in the Y-axis direction may be equal to that of the insulating island **13**.

[0073] Referring to FIG. **8**, the first insulating layer **105** is formed on an entire surface of the structure of FIG. **7**. Accordingly, the first insulating layer **105** completely covers the second active layer **220**, the lower electrode **310**, and the semiconductor island **20**.

[0074] Referring to FIG. **9**, a contact hole that exposes the second active layer **220** and an opening and a contact hole that expose the pixel electrode **410**, are formed on the structure of FIG. **8**, using a third mask. Accordingly, the pixel electrode **410** is exposed through the opening, by removing at a portion of the first insulating layer **105**.

[0075] Referring to FIG. **10**, the second source electrode **231** and the second drain electrode **232**, the upper electrode **330**, and the data line D are simultaneously formed from the same layer of material. More specifically, after forming a metal layer on an entire surface of the resultant structure of FIG. **9**, the second source electrode **231**, the second drain electrode **232**, the upper electrode **330**, and the data line D are patterned by using a fourth mask. At this point, the second source electrode **231** is connected to the second active layer **220** through the contact hole, and the second drain electrode **232** is connected to the second active layer **220** and the second electrode layer **412** of the pixel electrode **410** through the contact holes.

[0076] In the process of forming the structure of FIG. **10**, a first opening **1** that exposes the first electrode layer **411** is formed by etching a portion of the second electrode layer **412** of the pixel electrode **410**. As such, a portion of the first electrode layer **411** is exposed through the opening in the first insulating layer **105**.

[0077] Referring to FIG. **11**, the pixel-defining layer **107** is formed on an entire surface of the structure of FIG. **10**. Accordingly, the pixel-defining layer **107** covers the second source electrode **231**, the second drain electrode **232**, the upper electrode **330**, the data line D, and the pixel electrode **410**. A second opening **2** is formed by removing a portion of the pixel-defining layer **107** that faces the pixel electrode **410**.

[0078] The second opening **2** may be formed in the first opening **1**. In this way, a short circuit problem that can occur, due to the second electrode layer **412** of the pixel electrode **410** that surrounds the first opening **1**, can be prevented.

[0079] Referring to FIG. **12**, the organic light-emitting layer **420** is formed to directly contact the first electrode layer **411** through the second opening **2**. Also, the facing electrode **430** is formed on the organic light-emitting layer **420**.

[0080] The insulating island **13** and the semiconductor island **20** can be formed in the crossing region X, when manufacturing the first and second TFTs TR1 and TR2, without using any additional process. Also, the charge capacity of the capacitor Cst can be increased by interposing only the first insulating layer **105** between the lower electrode **310** and the upper electrode **330**, without using any additional process.

[0081] According to an exemplary embodiment of the present invention, an image having a high resolution can be realized by reducing the parasitic capacitance in the crossing region X and increasing the charge capacity of the capacitor Cst. Also, an economical method is provided, because the organic electroluminescence display can be manufactured by a reduced number of mask processes.

[0082] It will be apparent to those skilled in the art that various modifications and variation can be made in the present invention without departing from the spirit or scope of

the invention. Thus, it is intended that the present invention cover the modifications and variations of this invention provided they come within the scope of the appended claims and their equivalents.

What is claimed is:

1. An organic electroluminescence display comprising:
 - a substrate;
 - a gate line disposed on the substrate and extending in a first direction;
 - a data line disposed on the substrate and extending in a second direction substantially perpendicular to the first direction, the gate line and data line overlapping in a crossing region;
 - a first thin-film transistor (TFT) electrically connected to the gate line and the data line, comprising a gate electrode, an active layer that comprises an oxide semiconductor, a source electrode, a drain electrode, and a gate insulating layer interposed between the gate electrode and the active layer;
 - a capacitor electrically connected to the first TFT and comprising a lower electrode, and an upper electrode, each of the lower and upper electrodes comprising the same type of material as the source and drain electrodes;
 - a insulating layer interposed between the lower electrode and the upper electrode;
 - a second TFT electrically connected to the capacitor;
 - an organic light-emitting diode (OLED) electrically connected to the second TFT;
 - a semiconductor island disposed in the crossing region and separated from the active layer, the semiconductor island comprising the oxide semiconductor; and
 - a insulating island disposed in the crossing region, between the semiconductor island and the gate line, and comprising the same type of material as the gate insulating layer.
2. The organic electroluminescence display of claim 1, wherein:
 - the gate electrode extends from the gate line; and
 - the source electrode extends from the data line.
3. The organic electroluminescence display of claim 1, wherein the gate electrode comprises:
 - a first conductive layer that comprises a transparent conductive material; and
 - a second conductive layer disposed on the first conductive layer and comprising a low resistance conductive material.
4. The organic electroluminescence display of claim 1, wherein the insulating layer is disposed between the active layer and the source and drain electrodes.
5. The organic electroluminescence display of claim 1, wherein the insulating layer is also disposed between the semiconductor island and the data line, in the crossing region.
6. The organic electroluminescence display of claim 1, wherein the insulating island and the semiconductor island have the same size and shape.
7. The organic electroluminescence display of claim 1, wherein:
 - the widths of the semiconductor island and the insulating island extend in the first direction and are equal; and
 - the lengths of the semiconductor island and the insulating island extend in the second direction and are equal.
8. The organic electroluminescence display of claim 1, wherein the lower electrode and the gate electrode each comprise:

- a first layer that comprises a transparent conductive material; and
 a second layer disposed on the first layer and comprising a low resistance conductive material.
- 9.** The organic electroluminescence display of claim **1**, wherein the OLED comprises:
 a pixel electrode electrically connected to the second TFT;
 a facing electrode facing the pixel electrode; and
 an organic light-emitting layer interposed between the pixel electrode and the facing electrode.
- 10.** The organic electroluminescence display of claim **9**, wherein the pixel electrode comprises:
 a first electrode layer directly connected to the organic light-emitting layer and comprising a transparent conductive material; and
 a second electrode layer directly connected to the second TFT and comprising a low resistance conductive material.
- 11.** A method of manufacturing an organic electroluminescence display, the method comprising:
 patterning a first layer to form a gate electrode of a thin-film transistor (TFT), a lower electrode of a capacitor, and a gate line on a substrate;
 patterning a second layer to form a gate insulating layer on the gate electrode and an insulating island on the gate line, the insulating island being spaced apart from the gate insulating layer;
 patterning a third layer comprising an oxide semiconductor, to form an active layer on the gate insulating layer, and a semiconductor island on the insulating island, the semiconductor island being spaced apart from the active layer;
 forming an insulating layer on the active layer, the lower electrode, and the semiconductor island; and
 patterning a fourth layer to form a source electrode, a drain electrode, an upper electrode, and a data line on the insulating layer, the source and drain electrodes contacting the active layer, the upper electrode facing the lower electrode, and the data line extending across the gate line with the semiconductor island being disposed therebetween.
- 12.** The method of claim **11**, wherein the semiconductor island and the insulating island have the same size and shape.
- 13.** The method of claim **11**, wherein:
 the widths of the semiconductor island and the insulating island extend in the first direction and are equal; and
 the lengths of the semiconductor island and the insulating island extend in the second direction and are equal.
- 14.** The method of claim **11**, further comprising forming an organic light-emitting device (OLED) on the substrate, wherein,
 the patterning of the first layer further comprises forming a pixel electrode of the OLED, and
 the forming of the insulating layer further comprises forming the insulating layer on the pixel electrode.
- 15.** The method of claim **14**, wherein:
 the first layer comprises a transparent conductive layer disposed on the substrate and a low resistance conductive layer disposed on the transparent conductive layer; and
 the patterning of the first layer comprises patterning the first layer and the second layer to form the thin-film transistor (TFT), lower electrode, and the gate line.
- 16.** The method of claim **15**, further comprising forming a first opening in the insulating layer and the low resistance conductive layer of the pixel electrode, thereby exposing the transparent conductive layer of the pixel electrode.
- 17.** The method of claim **16**, further comprising forming a pixel-defining layer on the source electrode, the drain electrode, the upper electrode, the data line, and the pixel electrode.
- 18.** The method of claim **17**, further comprising forming a second opening in the pixel-defining layer, thereby exposing a portion of the transparent conductive layer of the pixel electrode.
- 19.** The method of claim **18**, further comprising forming an organic light-emitting layer directly on the exposed portion of the transparent conductive layer of the pixel electrode.
- 20.** The method of claim **19**, further comprising forming a facing electrode on the organic light-emitting layer.

* * * * *

专利名称(译)	有机电致发光显示器及其制造方法		
公开(公告)号	US20120292645A1	公开(公告)日	2012-11-22
申请号	US13/443485	申请日	2012-04-10
[标]申请(专利权)人(译)	三星显示有限公司		
申请(专利权)人(译)	三星移动显示器有限公司.		
当前申请(专利权)人(译)	三星DISPLAY CO. , LTD.		
[标]发明人	PARK SANG IL AHN TAE KYUNG		
发明人	PARK, SANG-IL AHN, TAE-KYUNG		
IPC分类号	H01L51/52 H01L51/56		
CPC分类号	H01L27/1225 H01L27/3248 H01L2227/323 H01L27/3265 H01L27/3276 H01L27/3262		
优先权	1020110047945 2011-05-20 KR		
其他公开文献	US8633490		
外部链接	Espacenet USPTO		

摘要(译)

一种有机电致发光显示器，包括：设置在基板上的栅极线；穿过栅极线的数据线；TFT连接到栅极线和数据线；连接到TFT的电容器；和连接到TFT的OLED。TFT的栅电极和电容器的下电极从第一层构图。设置在栅电极上的栅极绝缘层和设置在栅极线上的绝缘岛从第二层构图。设置在绝缘岛上的半导体岛和设置在栅极绝缘层上的有源层由第三层构图。绝缘层设置在TFT，电容器上以及半导体岛和数据线之间。从第四层图案化电容器的上电极，TFT的源/漏电极和数据线。

